

ANGLE HEAD SLIM WGX

MODULAR DESIGN

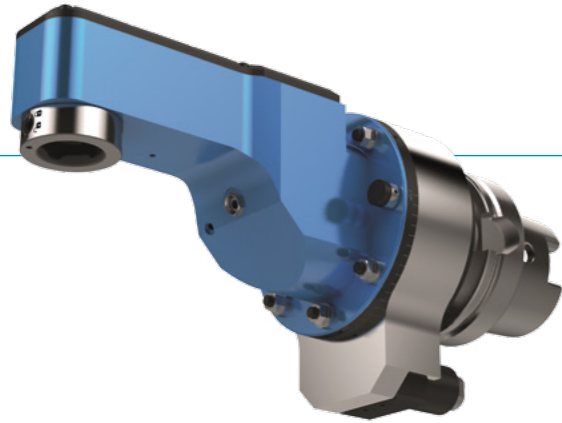

ANGLE HEAD BODY (SIZE)

05 07

OUTPUT SPINDLE / CLAMPING SYSTEM



BENZ
Solidfix®



Collet chuck

DRIVE CONE



SK
DIN 69871



MAS BT



CAT



HSK
DIN 69893



Coromant
Capto®



KM™

Angle head without IC

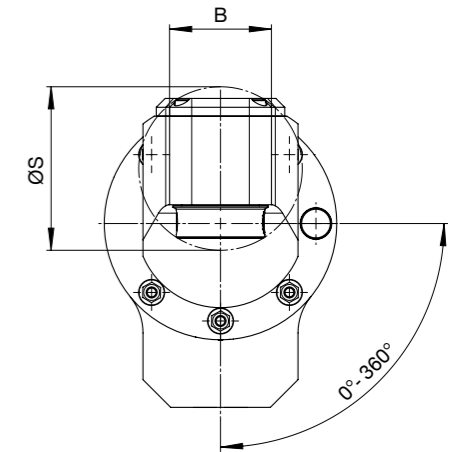
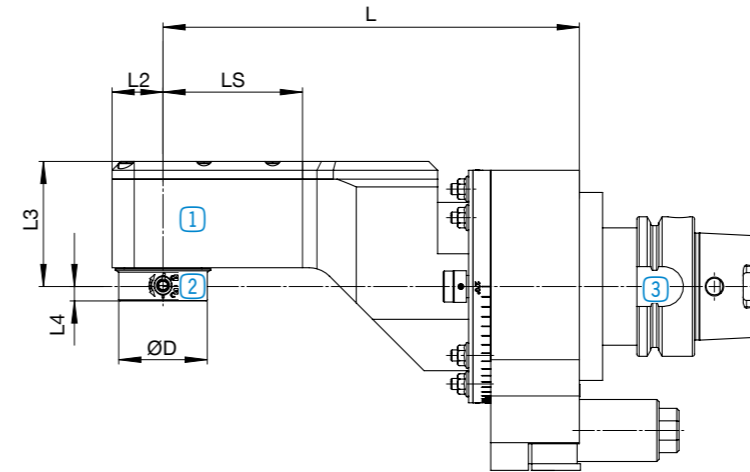

① Angle head body
page 46



② Output spindle /
clamping system
page 48

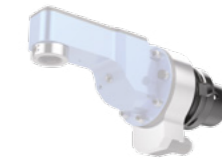

③ Drive cone
page 54

extremely narrow
design
page 50

Specifications

Change the angle head	Machining	Number of output spindles	Axis angle	Coolant feed for cutting edge

SLIM WGX

ANGLE HEAD SLIM WGX

▶ ANGLE HEAD BODY (SIZE)

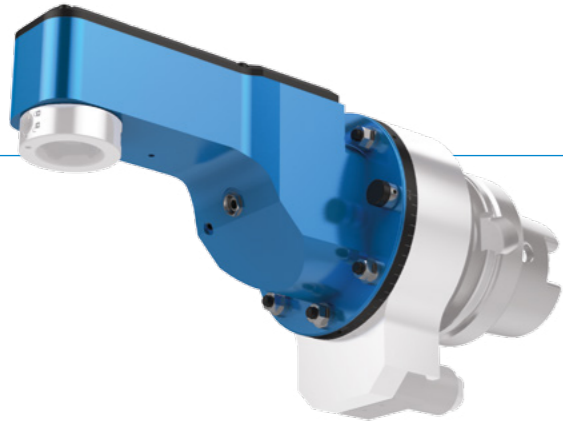

i More sizes on request.
Higher speeds are possible as an option.

▶ Angle head without IC

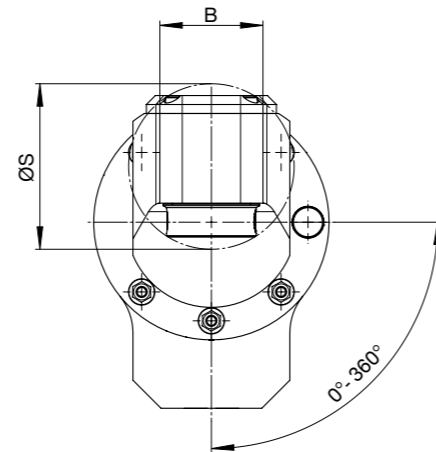
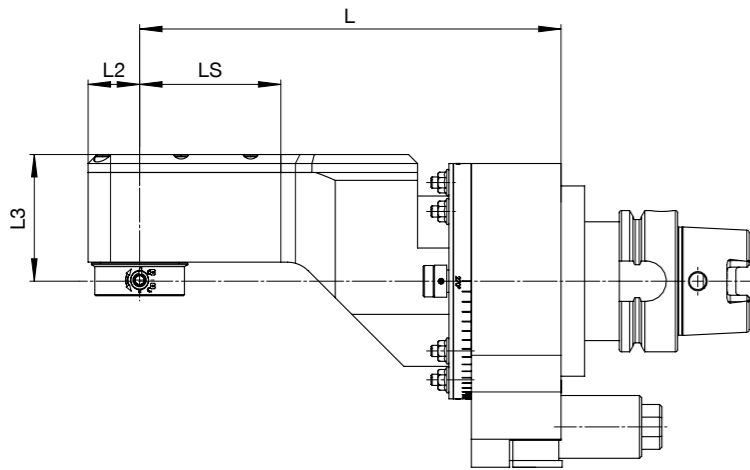

Size 05 / L2=16

$M_{2\max}$	= 12 Nm
i	= 1:1,607
$n_{2\max}$	= 8,000 rpm
p_{\max}	= 100 bar

▶ Technical data

LS [mm]	L2 [mm]	L3 [mm]	B [mm]	ØS [mm]	L [mm]	EC*	IC	Weight [kg]
24.2					149.2	- / ✓		5
56.2	16	56	40	63	181.2	- / ✓	-	5.2
88.2					213.2	- / ✓		5.4

Size 05 / L2=18

$M_{2\max}$	= 15 Nm
i	= 1:1,452
$n_{2\max}$	= 8,000 rpm
p_{\max}	= 100 bar

▶ Technical data

LS [mm]	L2 [mm]	L3 [mm]	B [mm]	ØS [mm]	L [mm]	EC*	IC	Weight [kg]
25.4					150.4	- / ✓		5.2
57.4	18	58.5	40	71	182.4	- / ✓	-	5.3
89.4					213.4	- / ✓		5.4

Size 05 / L2=23

M_{\max}	= 15 Nm
i	= 1:1
n_{\max}	= 8,000 rpm
p_{\max}	= 100 bar

▶ Technical data

LS [mm]	L2 [mm]	L3 [mm]	B [mm]	ØS [mm]	L [mm]	EC*	IC	Weight [kg]
31					156	- / ✓		5.4
63	23	56.5	46	74	188	- / ✓	-	5.5
95					220	- / ✓		5.7

Size 07

M_{\max}	= 35 Nm
i	= 1:1
n_{\max}	= 6,000 rpm
p_{\max}	= 100 bar

▶ Technical data

LS [mm]	L2 [mm]	L3 [mm]	B [mm]	ØS [mm]	L [mm]	EC*	IC	Weight [kg]
54					178	- / ✓		9
85	26	65	52	78	215	- / ✓	-	9.5
160					290	- / ✓		10

i *Optional: EC via spray nozzle

i $M_{2\max}$ = output torque
 $n_{2\max}$ = output speed

ANGLE HEAD SLIM WGX

▶ OUTPUT SPINDLE / CLAMPING SYSTEM

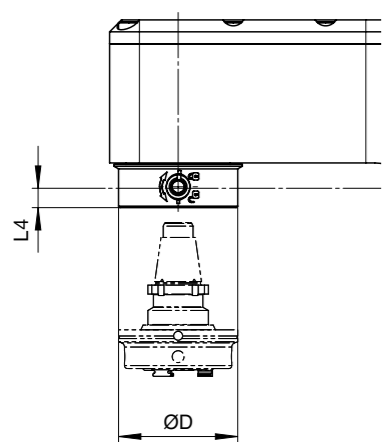
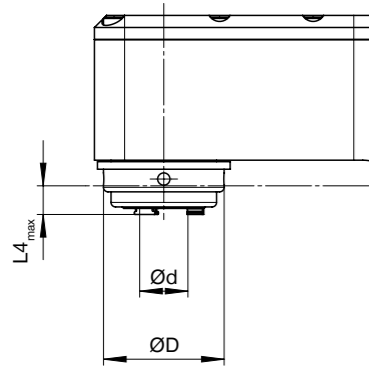
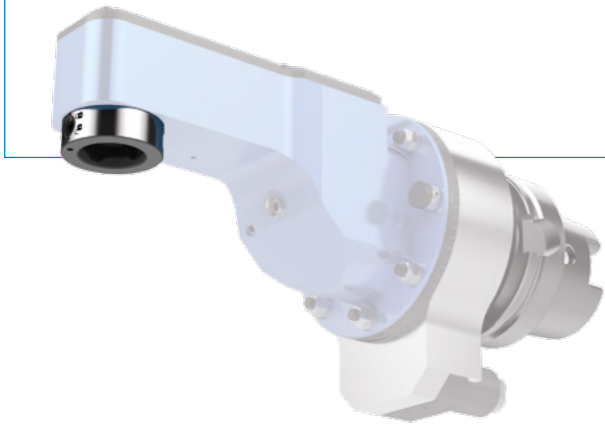

▶ Technical data				
Collet chuck	Size	L4 _{max} [mm]	ØD [mm]	Ød _{max} [mm]
ER11A	05 (L2=16)	1	30	7
ER16A	05 (L2=18)	7	44	10
ER20A	05 (L2=23)	10	44	13
ER25A	07	4	47	16



i For adapters and dimensions, see catalogue **BENZ Modular Tool Systems**

▶ Technical data			
BENZ Solidfix®	Size	L4 [mm]	ØD [mm]
S2	05 (L2=23)	6.5	40
S3	07	2.5	50



ANGLE HEAD SLIM WGX-S

▶ EXTREMELY NARROW DESIGN

▶ Angle head without IC

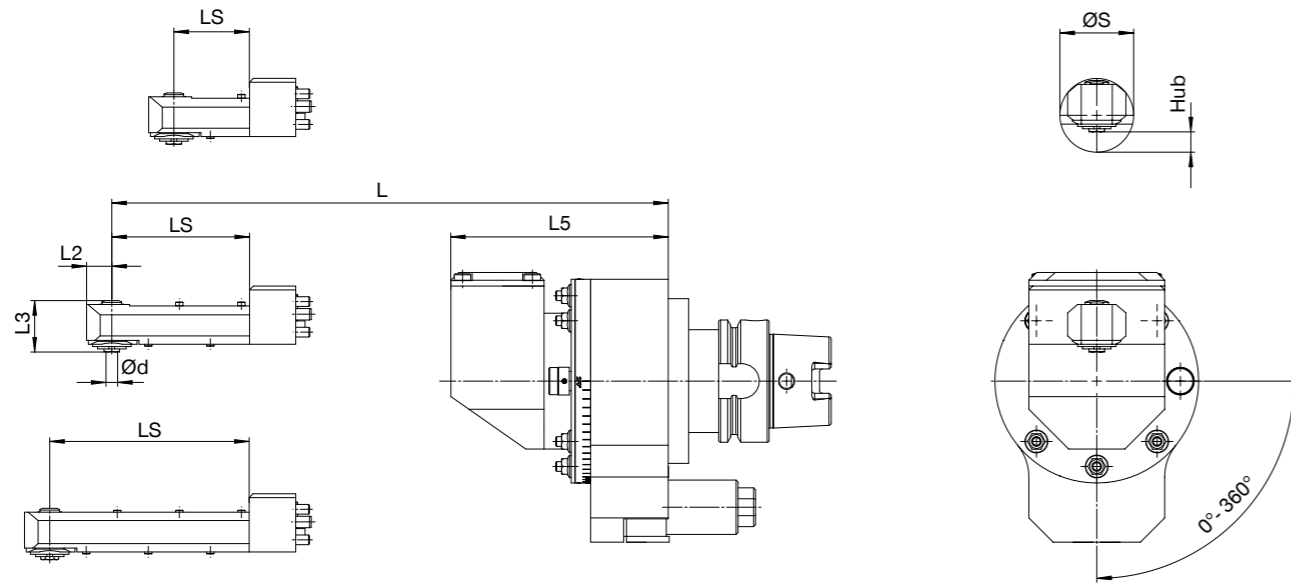

		▶ Technical data										
Size 05 / ØS=25		LS [mm]	L2 [mm]	L3 [mm]	L5 [mm]	Ød [mm]	ØS [mm]	L [mm]	Hub [mm]	EC*	IC	Weight [kg]
$M_{2\max}$	= 3 Nm	31						167		- / ✓		3.7
i	= 1:2,38	57	12.5	20	112	4	25	193	4	- / ✓	-	3.8
$n_{2\max}$	= 8,000 rpm					Special						
p_{\max}	= 100 bar	96						232		- / ✓		3.9

		▶ Technical data										
Size 05 / ØS=29		LS [mm]	L2 [mm]	L3 [mm]	L5 [mm]	Ød [mm]	ØS [mm]	L [mm]	Hub [mm]	EC*	IC	Weight [kg]
$M_{2\max}$	= 3 Nm	32						168		- / ✓		3.8
i	= 1:2,19	71	13.5	20	112	4	29	207	6	- / ✓	-	3.9
$n_{2\max}$	= 8,000 rpm					Special						
p_{\max}	= 100 bar	97						233		- / ✓		4.0

		▶ Technical data										
Size 05 / ØS=32		LS [mm]	L2 [mm]	L3 [mm]	L5 [mm]	Ød [mm]	ØS [mm]	L [mm]	Hub [mm]	EC*	IC	Weight [kg]
$M_{2\max}$	= 5 Nm	37						173		- / ✓		3.8
i	= 1:2,273	69	12	26,5	112	5	32	205	9	- / ✓	-	4
$n_{2\max}$	= 8,000 rpm					Special						
p_{\max}	= 100 bar	95						231		- / ✓		4.2

*Optional: EC via spray nozzle

$M_{2\max}$ = output torque
 $n_{2\max}$ = output speed

▶ EXTREMELY NARROW DESIGN

▶ Angle head without EC+IC / Output spindle: Whistle Notch

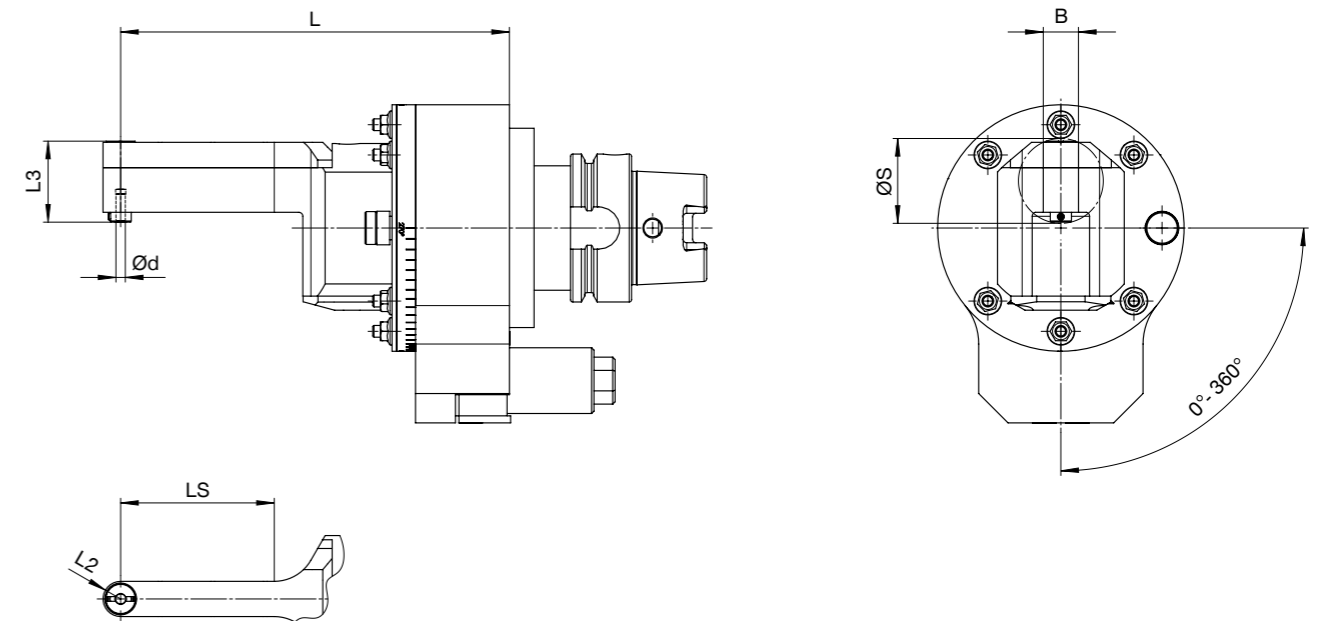

		▶ Technical data										
Size 05 / L2=7.5		LS [mm]	L2 [mm]	L3 [mm]	Ød [mm]	B [mm]	ØS [mm]	L [mm]	EC	IC	Weight [kg]	
$M_{2\max}$	= 3 Nm	66	7.5	34.5	4	15	37	166	-	-	5.4	
i	= 1:2,07					DIN 1835E						
$n_{2\max}$	= 8,000 rpm											

		▶ Technical data										
Size 05 / L2=9.5		LS [mm]	L2 [mm]	L3 [mm]	Ød [mm]	B [mm]	ØS [mm]	L [mm]	EC	IC	Weight [kg]	
$M_{2\max}$	= 5 Nm	45			6	19	39.4	143	-	-	5.4	
i	= 1:1,61	73	9.5	37		DIN 1835E		172			5.6	
$n_{2\max}$	= 8,000 rpm											

also available with Weldon output spindle

$M_{2\max}$ = output torque
 $n_{2\max}$ = output speed

ANGLE HEAD SLIM WGX-S

▶ EXTREMELY NARROW DESIGN

▶ Angle head without IC / Output spindle: Nann-Collet Chuck

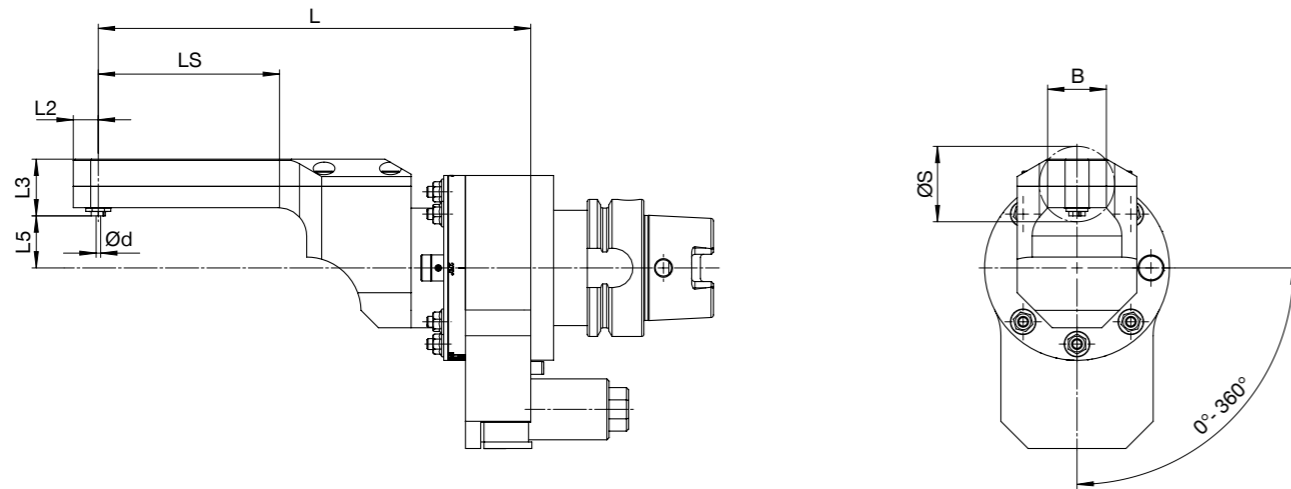

Size 04 / L2=11.5

$M_{2\max}$	= 8 Nm
i	= 1:1,708
$n_{2\max}$	= 10,000 rpm
p_{\max}	= 50 bar

▶ Technical data

LS [mm]	L2 [mm]	L3 [mm]	L5 [mm]	B [mm]	Ød [mm]	ØS [mm]	L [mm]	EC*	IC	Weight [kg]
38.5					4		154	- / ✓		3.7
83	11.5	28	22	27	DIN 6043 E	35	199	- / ✓	-	3.8
128							244	- / ✓		3.9

Size 04 / L2=14

$M_{2\max}$	= 10 Nm
i	= 1:1,367
$n_{2\max}$	= 8,000 rpm
p_{\max}	= 50 bar

▶ Technical data

LS [mm]	L2 [mm]	L3 [mm]	L5 [mm]	B [mm]	Ød [mm]	ØS [mm]	L [mm]	EC*	IC	Weight [kg]
42.5					6		158	- / ✓		3.8
89	14	38	14	30	DIN E603E-3	44	205	- / ✓	-	3.9
135							251	- / ✓		4.1

*Optional: EC via spray nozzle

further Nann-Collet Chucks on request

$M_{2\max}$ = output torque
 $n_{2\max}$ = output speed



ANGLE HEAD SLIM WGX

DRIVE CONE

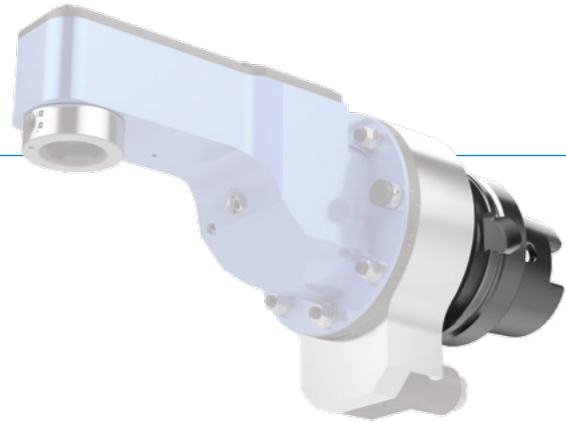

i Technical data for other machine interfaces on request.

Type: Steep taper



	Size		
	04	05	07
SK DIN 69871			
SK 40	✓	✓	✓
SK 50	✓	✓	✓



	Size		
	04	05	07
MAS BT			
BT 40	✓	✓	✓
BT 50	✓	✓	✓



	Size		
	04	05	07
CAT			
CAT 40	✓	✓	✓
CAT 50	✓	✓	✓

Type: Hollow shank taper



	Size		
	04	05	07
HSK DIN 69893			
HSK 40	✓	-	-
HSK 50	✓	✓	-
HSK 63	✓	✓	✓
HSK 80	✓	✓	✓
HSK 100	✓	✓	✓



	Size		
	04	05	07
Coromant Capto®			
C3	✓	-	-
C4	✓	✓	-
C5	✓	✓	✓
C6	✓	✓	✓
C8	✓	✓	✓



	Size		
	04	05	07
Kennametal™			
KM 40	✓	-	-
KM 50	✓	✓	-
KM 63	✓	✓	✓
KM 80	✓	✓	✓
KM 100	✓	✓	✓