

# LIVE TOOL BMT 55-83

## AXIAL, BROACHING UNIT - BENZ LINA 4.0

### TECHNICAL DATA



i.com

LENGTH L1

88

OUTPUT SPINDLE



Prism-shaped profile  
Ø 30 mm

**i** For questions regarding BENZ i.com please contact our BENZ Sales Team

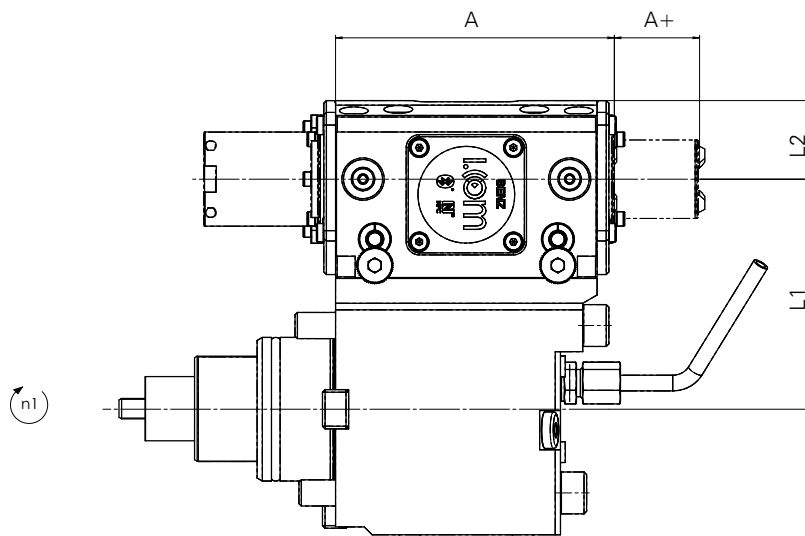
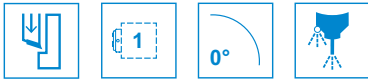

#### Performance Data

Type	$n_{1\max} / *n_{2\max}$ [min <sup>-1</sup> ]	$M_{1\max} / F_{c\max}$ [Nm]	f [mm]	Groove width <sub>max</sub> [mm]
ES	1500 / 1500	30 / 1700	0,02 - 0,10	12

#### Technical Data

Type	Size	i	EC	IC p <sub>max</sub> [bar]	**A+	A [mm]	L1 [mm]	L2 [mm]	Order No.
ES	30	1:1	✓	50	32 / 34	106,5	88	30	113ES07807B2D-88-IB

\*number of double stroke per minute

\*\*usable working stroke / total stroke