

NEW メントリドリル

NEW Chamfering Drill

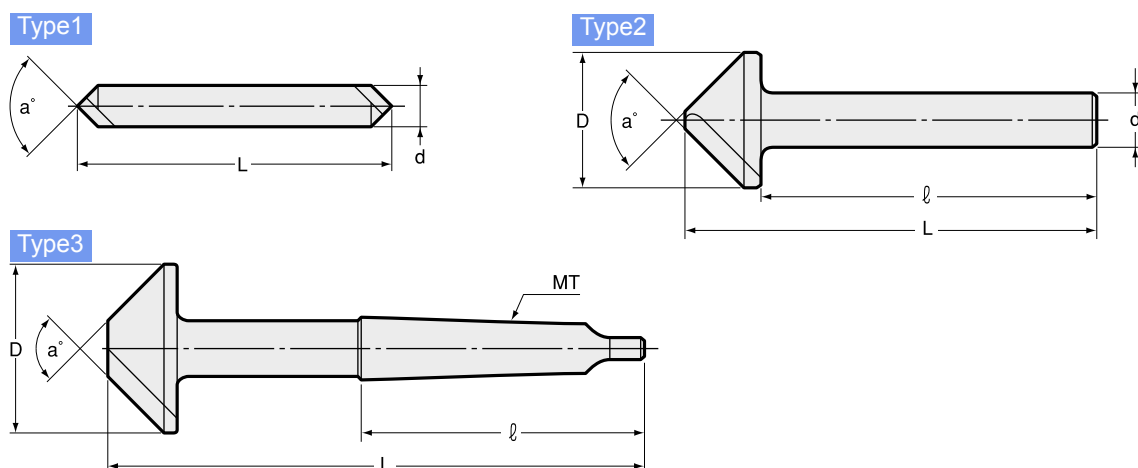

用途 Application

硬く、粘りのない材質の加工用。アルミニウム合金、銅合金等の軟らかく、延性(粘り)の高い材質を加工される場合は、従来の『メントリドリル』をご使用ください。
For hard and indutible material. When machining soft and ductile material (such as aluminum alloy and copper alloy), please use "CHAMFERING DRILL"

ST

商品コード Code	型式 Model	刃角 a° Angle	面取り径 Chamfering dia.	Type	d h7	D	ℓ	L	—	再研磨
0010 00007890	07 -ST8 -90°	90°	1.5 ~ 7	1	8	—	—	55	2,800	1,300
0010 00015890	15 -ST8 -90°	90°	2 ~ 15	2	8	16	54	65	3,200	1,100
0010 00251090	25 -ST10 -90°	90°	6 ~ 25	2	10	26	65	80	5,300	1,800
0010 00351290	35 -ST12 -90°	90°	11 ~ 35	2	12	36	74	90	8,400	2,800
0010 00451290	45 -ST12 -90°	90°	16 ~ 45	2	12	46	76	95	11,600	3,900
0010 00007860	07 -ST8 -60°	60°	1.5 ~ 7	1	8	—	—	55	3,500	1,300
0010 00015860	15 -ST8 -60°	60°	6 ~ 15	2	8	16	53	65	4,000	1,100
0010 00251060	25 -ST10 -60°	60°	12 ~ 25	2	10	26	64	80	6,700	1,800
0010 00351260	35 -ST12 -60°	60°	20 ~ 35	2	12	36	73	90	10,500	2,800
0010 00451260	45 -ST12 -60°	60°	26 ~ 45	2	12	46	74	95	14,500	3,900
0010 00078120	07 -ST8 -120°	120°	1.5 ~ 7	1	8	—	—	55	3,800	1,300
0010 00158120	15 -ST8 -120°	120°	2 ~ 15	2	8	16	52	60	4,400	1,100
0010 02510120	25 -ST10 -120°	120°	6 ~ 25	2	10	26	65	75	7,200	1,800
0010 03512120	35 -ST12 -120°	120°	11 ~ 35	2	12	36	74	85	11,400	2,800
0010 04512120	45 -ST12 -120°	120°	16 ~ 45	2	12	46	73	85	15,700	3,900

MT

商品コード Code	型式 Model	刃角 a° Angle	面取り径 Chamfering dia.	Type	MT	D	ℓ	L	—	再研磨
0010 00015190	15 -MT1 -90°	90°	2 ~ 15	3	1	16	65	120	5,400	1,800
0010 00015290	-MT2 -90°	90°	2 ~ 15	3	2	16	80	140	5,700	1,800
0010 00025190	25 -MT1 -90°	90°	6 ~ 25	3	1	26	65	125	9,000	3,000
0010 00025290	-MT2 -90°	90°	6 ~ 25	3	2	26	80	145	9,500	3,000
0010 00035290	35 -MT2 -90°	90°	11 ~ 35	3	2	36	80	145	14,300	4,000
0010 00035390	-MT3 -90°	90°	11 ~ 35	3	3	36	100	180	15,200	4,000
0010 00045290	45 -MT2 -90°	90°	16 ~ 45	3	2	46	80	150	19,700	5,000
0010 00045390	-MT3 -90°	90°	16 ~ 45	3	3	46	100	185	20,800	5,000

ご注文例 Ordering Example

15 - ST 8 - 90°
 面取り最大径 Max. chamfering dia. | シャンクサイズ Shank size | 刃角 Angle
 ストレートシャンク Straight shank

ご注文例 Ordering Example

15 - MT 1 - 90°
 面取り最大径 Max. chamfering dia. | MT1 | 刃角 Angle
 モールステーパシャンク Morse taper shank