



GDZ-R

高バランスタイプ "R"ゼロホルダ RCキャップ仕様
"R" Zero Holder with RC Nut (High-Balanced Type)



刃先の振れを限りなく「ゼロ」に調整できる画期的なホルダです。(高バランスタイプ)



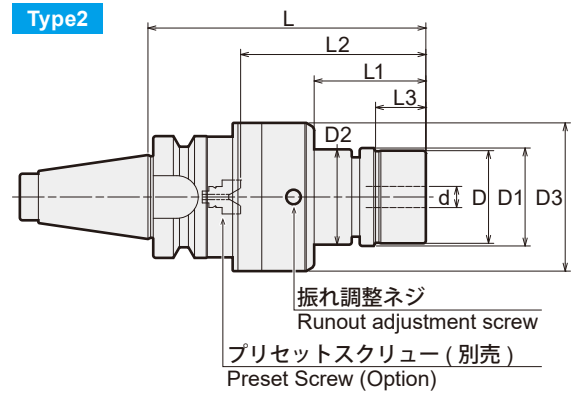
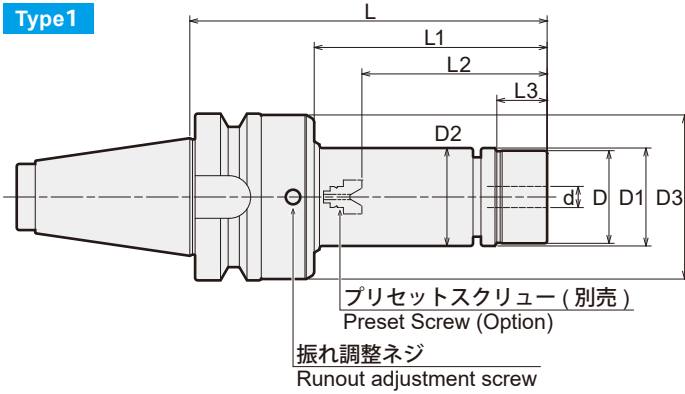

Runout accuracy of the cutting edge can be adjusted as closely as zero. (High-balanced type)



商品コード Code	型式 Model	Type	d	L	L1	L2	L3	D	D1	D2	D3	キャップ Nut	kg	—	コレット Collet	レンチ Wrench	振れ調整 レンチ Adjustment wrench
3127 00107060	BT30 -GDZ07 -60(R)	1	0.5 ~ 7.0	60	22	22 ~ 45	—	20	—	23	41	HDP-07R	0.6	41,580	FDC-07AA	S-0R	L-3T
3127 00107075	-75(R)	1	0.5 ~ 7.0	75	37	22 ~ 45	—	20	—	23	41	HDP-07R	0.6	42,120			
3127 00107090	-90(R)	1	0.5 ~ 7.0	90	52	22 ~ 45	—	20	—	23	41	HDP-07R	0.7	42,760			
3127 00107105	-105(R)	1	0.5 ~ 7.0	105	67	22 ~ 45	—	20	—	23	41	HDP-07R	0.7	43,740	FDC-09AA	S-1R	L-3T
3127 00109075	-GDZ09 -75(R)	1	2.5 ~ 9.0	75	28	27 ~ 57	18	26	29	29	41	GDP-09R	0.7	42,120			
3127 00109090	-90(R)	1	2.5 ~ 9.0	90	43	27 ~ 57	18	26	29	29	41	GDP-09R	0.8	43,740			
3127 00109105	-105(R)	1	2.5 ~ 9.0	105	58	27 ~ 57	18	26	29	29	41	GDP-09R	0.8	44,820	FDC-12AA	S-3R	L-4T
3127 00112105	-GDZ12 -105(R)	2	2.5 ~ 12.0	105	42	33 ~ 69	19	30	32	34	52	GDP-12R	1.1	48,060			
3127 00112120	-120(R)	2	2.5 ~ 12.0	120	57	33 ~ 69	19	30	32	34	52	GDP-12R	1.2	49,140			
3127 00112135	-135(R)	2	2.5 ~ 12.0	135	72	33 ~ 69	19	30	32	34	52	GDP-12R	1.3	50,220	FDC-16AA	S-4R	L-4T
3127 00116105	-GDZ16 -105(R)	2	3.5 ~ 16.0	105	42	38 ~ 82	19	35	37	38	56	GDP-16R	1.2	48,920			
3127 00116120	-120(R)	2	3.5 ~ 16.0	120	57	38 ~ 82	19	35	37	38	56	GDP-16R	1.3	50,000			
3127 00116135	-135(R)	2	3.5 ~ 16.0	135	72	38 ~ 82	19	35	37	38	56	GDP-16R	1.4	51,300	FDC-07AA	S-0R	L-3T
3127 00307090	BT40 -GDZ07 -90(R)	1	0.5 ~ 7.0	90	43	22 ~ 45	—	20	—	23	41	HDP-07R	1.3	46,440			
3127 00307105	-105(R)	1	0.5 ~ 7.0	105	58	22 ~ 45	—	20	—	23	41	HDP-07R	1.3	46,980			
3127 00307120	-120(R)	1	0.5 ~ 7.0	120	73	22 ~ 45	—	20	—	23	41	HDP-07R	1.3	47,520	FDC-09AA	S-1R	L-3T
3127 00309090	-GDZ09 -90(R)	1	2.5 ~ 9.0	90	43	27 ~ 57	18	26	28	29	45	GDP-09R	1.3	47,520			
3127 00309105	-105(R)	1	2.5 ~ 9.0	105	58	27 ~ 57	18	26	28	29	45	GDP-09R	1.4	49,030			
3127 00309120	-120(R)	1	2.5 ~ 9.0	120	73	27 ~ 57	18	26	28	29	45	GDP-09R	1.5	49,140	FDC-12AA	S-3R	L-4T
3127 00309135	-135(R)	1	2.5 ~ 9.0	135	88	27 ~ 57	18	26	28	29	45	GDP-09R	1.5	49,680			
3127 00309165	-165(R)	1	2.5 ~ 9.0	165	118	27 ~ 57	18	26	28	29	45	GDP-09R	1.6	50,760			
3127 00312790	-GDZ12 -90(R)	1	2.5 ~ 12.0	90	39	33 ~ 69	19	30	32	34	56	GDP-12R	1.5	49,140	FDC-12AA	S-3R	L-4T
3127 00312105	-105(R)	1	2.5 ~ 12.0	105	54	33 ~ 69	19	30	32	34	56	GDP-12R	1.6	50,760			
3127 00312120	-120(R)	1	2.5 ~ 12.0	120	69	33 ~ 69	19	30	32	34	56	GDP-12R	1.7	52,380			
3127 00312135	-135(R)	1	2.5 ~ 12.0	135	84	33 ~ 69	19	30	32	34	56	GDP-12R	1.8	53,460	FDC-16AA	S-4R	L-4T
3127 00312165	-165(R)	1	2.5 ~ 12.0	165	114	33 ~ 69	19	30	32	34	56	GDP-12R	2.0	54,540			
3127 00312195	-195(R)	1	2.5 ~ 12.0	195	144	33 ~ 69	19	30	32	34	56	GDP-12R	2.1	55,620			
3127 00316090	-GDZ16 -90(R)	1	3.5 ~ 16.0	90	43	38 ~ 82	19	35	37	38	62	GDP-16R	1.6	52,920	FDC-16AA	S-4R	L-4T
3127 00316105	-105(R)	1	3.5 ~ 16.0	105	58	38 ~ 82	19	35	37	38	62	GDP-16R	1.7	53,460			
3127 00316120	-120(R)	1	3.5 ~ 16.0	120	73	38 ~ 82	19	35	37	38	62	GDP-16R	1.8	53,780			
3127 00316135	-135(R)	1	3.5 ~ 16.0	135	88	38 ~ 82	19	35	37	38	62	GDP-16R	1.9	54,320	FDC-22AA	S-5R	L-6T
3127 00316165	-165(R)	1	3.5 ~ 16.0	165	118	38 ~ 82	19	35	37	38	62	GDP-16R	2.1	55,940			
3127 00316195	-195(R)	1	3.5 ~ 16.0	195	148	38 ~ 82	19	35	37	38	62	GDP-16R	2.3	57,020			
3127 10322120	-GDZ22A -120(R)	2	3.5 ~ 22.0	120	40	47 ~ 103	24	46	48	49	69	GDP-22R	2.4	55,720	FDC-22AA	S-5R	L-6T
3127 10322135	-135(R)	2	3.5 ~ 22.0	135	55	47 ~ 103	24	46	48	49	69	GDP-22R	2.6	56,800			
3127 10322165	-165(R)	2	3.5 ~ 22.0	165	85	47 ~ 103	24	46	48	49	69	GDP-22R	2.9	58,420			
3127 10322195	-195(R)	2	3.5 ~ 22.0	195	115	47 ~ 103	24	46	48	49	69	GDP-22R	3.2	59,500			

商品コード Code	型式 Model	Type	d	L	L1	L2	L3	D	D1	D2	D3	キャップ Nut	kg	—	コレット Collet	レンチ Wrench	振れ調整 レンチ Adjustment wrench			
3127 00507090	BT50 -GDZ07 -90(R)	1	0.5 ~ 7.0	90	32	22 ~ 45	—	20	—	23	41	HDP-07R	3.7	55,620	FDC-07AA	S-0R	L-3T			
3127 00507105	-105(R)	1	0.5 ~ 7.0	105	47	22 ~ 45	—	20	—	23	41	HDP-07R	3.8	56,160						
3127 00507120	-120(R)	1	0.5 ~ 7.0	120	62	22 ~ 45	—	20	—	23	41	HDP-07R	3.9	56,700						
3127 00507135	-135(R)	1	0.5 ~ 7.0	135	77	22 ~ 45	—	20	—	23	41	HDP-07R	4.0	57,240						
3127 00507165	-165(R)	1	0.5 ~ 7.0	165	107	22 ~ 45	—	20	—	23	41	HDP-07R	4.1	59,400						
3127 00507195	-195(R)	1	0.5 ~ 7.0	195	137	22 ~ 45	—	20	—	23	41	HDP-07R	4.2	60,480						
3127 00509090	-GDZ09 -90(R)	1	2.5 ~ 9.0	90	32	27 ~ 57	18	26	28	29	45	GDP-09R	3.8	55,620	FDC-09AA	S-1R	L-3T			
3127 00509105	-105(R)	1	2.5 ~ 9.0	105	47	27 ~ 57	18	26	28	29	45	GDP-09R	3.9	56,160						
3127 00509120	-120(R)	1	2.5 ~ 9.0	120	62	27 ~ 57	18	26	28	29	45	GDP-09R	4.0	56,700						
3127 00509135	-135(R)	1	2.5 ~ 9.0	135	77	27 ~ 57	18	26	28	29	45	GDP-09R	4.0	57,240						
3127 00509165	-165(R)	1	2.5 ~ 9.0	165	107	27 ~ 57	18	26	28	29	45	GDP-09R	4.2	59,400						
3127 00509195	-195(R)	1	2.5 ~ 9.0	195	137	27 ~ 57	18	26	28	29	45	GDP-09R	4.3	60,480						
3127 00509225	-225(R)	1	2.5 ~ 9.0	225	167	27 ~ 57	18	26	28	29	45	GDP-09R	4.4	62,100						
3127 00509255	-255(R)	1	2.5 ~ 9.0	255	197	27 ~ 57	18	26	28	29	45	GDP-09R	4.6	62,640						
3127 00512105	-GDZ12 -105(R)	1	2.5 ~ 12.0	105	43	33 ~ 69	19	30	32	34	56	GDP-12R	4.0	61,560				FDC-12AA	S-3R	L-4T
3127 00512120	-120(R)	1	2.5 ~ 12.0	120	58	33 ~ 69	19	30	32	34	56	GDP-12R	4.1	62,100						
3127 00512135	-135(R)	1	2.5 ~ 12.0	135	73	33 ~ 69	19	30	32	34	56	GDP-12R	4.3	62,640						
3127 00512165	-165(R)	1	2.5 ~ 12.0	165	103	33 ~ 69	19	30	32	34	56	GDP-12R	4.5	64,800						
3127 00512195	-195(R)	1	2.5 ~ 12.0	195	133	33 ~ 69	19	30	32	34	56	GDP-12R	4.6	65,880						
3127 00512225	-225(R)	1	2.5 ~ 12.0	225	163	33 ~ 69	19	30	32	34	56	GDP-12R	4.8	66,420						
3127 00512255	-255(R)	1	2.5 ~ 12.0	255	193	33 ~ 69	19	30	32	34	56	GDP-12R	4.9	66,960						
3127 00516105	-GDZ16 -105(R)	1	3.5 ~ 16.0	105	43	38 ~ 82	19	35	37	38	62	GDP-16R	4.2	61,880	FDC-16AA	S-4R	L-4T			
3127 00516120	-120(R)	1	3.5 ~ 16.0	120	58	38 ~ 82	19	35	37	38	62	GDP-16R	4.3	62,420						
3127 00516135	-135(R)	1	3.5 ~ 16.0	135	73	38 ~ 82	19	35	37	38	62	GDP-16R	4.4	62,960						
3127 00516165	-165(R)	1	3.5 ~ 16.0	165	103	38 ~ 82	19	35	37	38	62	GDP-16R	4.6	65,120						
3127 00516195	-195(R)	1	3.5 ~ 16.0	195	133	38 ~ 82	19	35	37	38	62	GDP-16R	4.8	66,200						
3127 00516225	-225(R)	1	3.5 ~ 16.0	225	163	38 ~ 82	19	35	37	38	62	GDP-16R	5.0	67,280						
3127 00516255	-255(R)	1	3.5 ~ 16.0	255	193	38 ~ 82	19	35	37	38	62	GDP-16R	5.3	68,900						
3127 10522105	-GDZ22A -105(R)	1	3.5 ~ 22.0	105	39	47 ~ 103	24	46	48	49	76	GDP-22R	4.5	62,200	FDC-22AA	S-5R	L-6T			
3127 10522120	-120(R)	1	3.5 ~ 22.0	120	54	47 ~ 103	24	46	48	49	76	GDP-22R	4.7	63,180						
3127 10522135	-135(R)	1	3.5 ~ 22.0	135	69	47 ~ 103	24	46	48	49	76	GDP-22R	4.8	63,820						
3127 10522150	-150(R)	1	3.5 ~ 22.0	150	84	47 ~ 103	24	46	48	49	76	GDP-22R	5.0	64,900						
3127 10522165	-165(R)	1	3.5 ~ 22.0	165	99	47 ~ 103	24	46	48	49	76	GDP-22R	5.2	65,980						
3127 10522195	-195(R)	1	3.5 ~ 22.0	195	129	47 ~ 103	24	46	48	49	76	GDP-22R	5.6	67,060						
3127 10522225	-225(R)	1	3.5 ~ 22.0	225	159	47 ~ 103	24	46	48	49	76	GDP-22R	5.9	68,140						
3127 10522255	-255(R)	1	3.5 ~ 22.0	255	189	47 ~ 103	24	46	48	49	76	GDP-22R	6.2	69,760						

- コレット、レンチ、プリセットスクリュー、振れ調整レンチは別途ご注文下さい。
 - コレットは必ず AA 級をご使用下さい。
 - クーラントコレット (FDC-OH、C、MS) とタング付刃具併用時の最低挿入長は P.097 を参照下さい。
 - L2 はプリセットスクリューを使用した時の値です。
 - キャップの締め付けトルクに関しては、P.554 を参照ください。
- Collet, preset screw, wrench and adjustment wrench are sold separately.
 - Always use AA class collet.
 - Refer to P. 097 for minimum tool insertion length in case of using our coolant collets (OH,C or MS).
 - "L2" indicates dimension when using with a preset screw.
 - See P. 554 for standard tightening torque.

コレット Collet P. 092	レンチ Wrench P. 098	プリセットスクリュー Preset screw P. 100	振れ調整レンチ Adjustment wrench P. 099
			

ご注文例 Ordering Example

BT40 - GDZ09 - 90 (R)
 シャンクサイズ 最大コレット内径 突き出し長さ(L) RCキャップ仕様
 Shank size Max. collet I.D. Projection length with RC Nut



GDZ-R

高バランスタイプ "R"ゼロホルダ RCキャップ仕様
"R" Zero Holder with RC Nut (High-Balanced Type)



刃先の振れを限りなく「ゼロ」に調整できる画期的なホルダです。(高バランスタイプ)
Runout accuracy of the cutting edge can be adjusted as closely as zero. (High-balanced type)

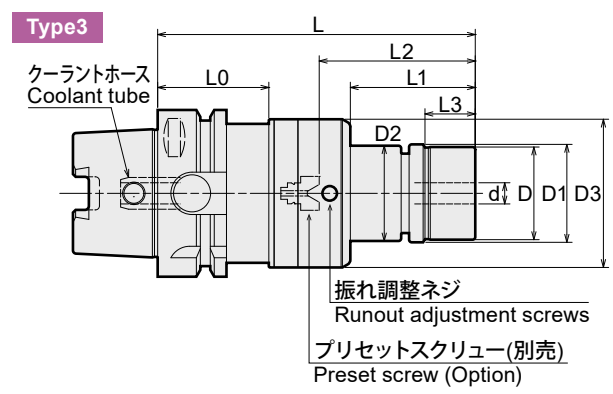
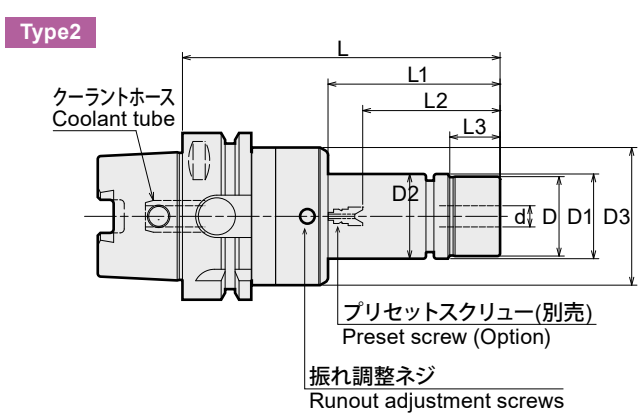
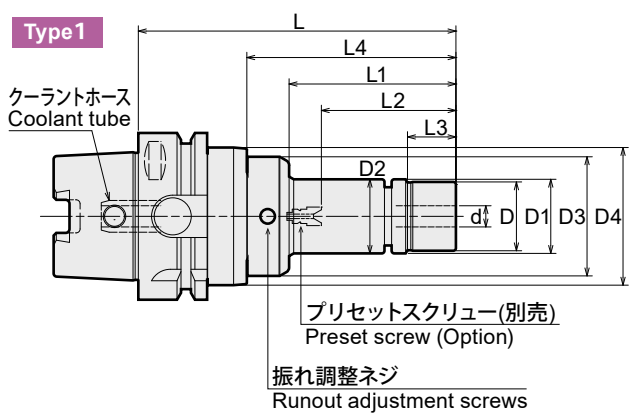





商品コード Code	型式 Model	Type	d	L	L1	L2	L3	L4	D	D1	D2	D3	D4	L0	キャップ Nut	kg	—	コレット Collet	レンチ Wrench	振れ調整 レンチ Adjustment wrench
5677 13007075	HSK40A -GDZ07 - 75(R)	2	0.5~7.0	75	30	22~30	—	—	20	—	23	34	—	—	HDP-07R	0.4	46,440	FDC-07AA	S-0R	L-3T
5677 13007090	- 90(R)	2	0.5~7.0	90	45	22~45	—	—	20	—	23	34	—	—	HDP-07R	0.5	47,520			
5677 13007120	-120(R)	2	0.5~7.0	120	75	22~45	—	—	20	—	23	34	—	—	HDP-07R	0.5	49,140			
5677 13009090	-GDZ09 - 90(R)	3	2.5~9.0	90	28	27~42	18	—	26	28	29	41	—	35	GDP-09R		48,600	FDC-09AA	S-1R	L-3T
5677 13009120	-120(R)	3	2.5~9.0	120	58	27~57	18	—	26	28	29	41	—	35	GDP-09R	0.7	50,220			
5677 13009135	-135(R)	3	2.5~9.0	135	73	27~57	18	—	26	28	29	41	—	35	GDP-09R		50,760			
5677 13012105	-GDZ12 -105(R)	3	2.5~12.0	105	39	33~54	19	—	30	32	34	52	—	35	GDP-12R		54,000	FDC-12AA	S-3R	L-4T
5677 13012120	-120(R)	3	2.5~12.0	120	54	33~69	19	—	30	32	34	52	—	35	GDP-12R		55,080			
5677 13012150	-150(R)	3	2.5~12.0	150	84	33~69	19	—	30	32	34	52	—	35	GDP-12R		57,240			
5677 13016105	-GDZ16 -105(R)	3	3.5~16.0	105	39	38~57	19	—	35	37	38	56	—	35	GDP-16R		54,540	FDC-16AA	S-4R	L-4T
5677 13016120	-120(R)	3	3.5~16.0	120	54	38~72	19	—	35	37	38	56	—	35	GDP-16R		55,620			
5677 13016150	-150(R)	3	3.5~16.0	150	84	38~82	19	—	35	37	38	56	—	35	GDP-16R		57,780			
5677 14007090	HSK50A -GDZ07 - 90(R)	2	0.5~7.0	90	39	22~45	—	—	20	—	23	41	—	—	HDP-07R		55,620	FDC-07AA	S-0R	L-3T
5677 14007120	-120(R)	2	0.5~7.0	120	69	22~45	—	—	20	—	23	41	—	—	HDP-07R		56,160			
5677 14007135	-135(R)	2	0.5~7.0	135	84	22~45	—	—	20	—	23	41	—	—	HDP-07R		56,700			
5677 14009090	-GDZ09 - 90(R)	2	2.5~9.0	90	39	27~46	18	—	26	28	29	41	—	—	GDP-09R		56,700	FDC-09AA	S-1R	L-3T
5677 14009120	-120(R)	2	2.5~9.0	120	69	27~57	18	—	26	28	29	41	—	—	GDP-09R		58,860			
5677 14009135	-135(R)	2	2.5~9.0	135	84	27~57	18	—	26	28	29	41	—	—	GDP-09R		59,400			
5677 14012105	-GDZ12 -105(R)	3	2.5~12.0	105	32	33~58	19	—	30	32	34	52	—	42	GDP-12R		61,020	FDC-12AA	S-3R	L-4T
5677 14012120	-120(R)	3	2.5~12.0	120	47	33~69	19	—	30	32	34	52	—	42	GDP-12R		62,640			
5677 14012150	-150(R)	3	2.5~12.0	150	77	33~69	19	—	30	32	34	52	—	42	GDP-12R		64,800			
5677 14016105	-GDZ16 -105(R)	3	3.5~16.0	105	32	38~53	19	—	35	37	38	56	—	42	GDP-16R		64,260	FDC-16AA	S-4R	L-4T
5677 14016120	-120(R)	3	3.5~16.0	120	47	38~68	19	—	35	37	38	56	—	42	GDP-16R	1.3	64,800			
5677 14016150	-150(R)	3	3.5~16.0	150	77	38~82	19	—	35	37	38	56	—	42	GDP-16R		66,960			

商品コード Code	型式 Model	Type	d	L	L1	L2	L3	L4	D	D1	D2	D3	D4	L0	キャップ Nut	kg	—	コレット Collet	レンチ Wrench	振れ調整 レンチ Adjustment wrench
5677 75007090	HSK63A -GDZ07 - 90-H(R)	1	0.5-7.0	90	33	22~45	—	49	20	—	23	41	52	—	HDP-07R	1.1	57,780	FDC-07AA	S-0R	L-3T
5677 75007120	-120-H(R)	1	0.5-7.0	120	63	22~45	—	79	20	—	23	41	52	—	HDP-07R	1.2	58,320			
5677 75007135	-135-H(R)	1	0.5-7.0	135	78	22~45	—	94	20	—	23	41	52	—	HDP-07R	0.1	58,860			
5677 75009090	-GDZ09 - 90-H(R)	1	2.5-9.0	90	33	27~42	18	49	26	28	29	45	52	—	GDP-09R	1.1	58,860	FDC-09AA	S-1R	L-3T
5677 75009120	-120-H(R)	1	2.5-9.0	120	63	27~57	18	79	26	28	29	45	52	—	GDP-09R	1.3	61,020			
5677 75009135	-135-H(R)	1	2.5-9.0	135	78	27~57	18	94	26	28	29	45	52	—	GDP-09R	1.3	61,560			
5677 75012105	-GDZ12 -105-H(R)	2	2.5-12.0	105	50	33~54	19	—	30	32	34	52	—	—	GDP-12R	1.3	63,180	FDC-12AA	S-3R	L-4T
5677 75012120	-120-H(R)	2	2.5-12.0	120	65	33~69	19	—	30	32	34	52	—	—	GDP-12R	1.4	64,800			
5677 75012150	-150-H(R)	2	2.5-12.0	150	95	33~69	19	—	30	32	34	52	—	—	GDP-12R	1.5	66,960			
5677 75016105	-GDZ16 -105-H(R)	3	3.5-16.0	105	32	38~57	19	—	35	37	38	56	—	42	GDP-16R	1.6	66,420	FDC-16AA	S-4R	L-4T
5677 75016120	-120-H(R)	3	3.5-16.0	120	47	38~67	19	—	35	37	38	56	—	42	GDP-16R	1.6	66,960			
5677 75016150	-150-H(R)	3	3.5-16.0	150	77	38~82	19	—	35	37	38	56	—	42	GDP-16R	1.9	69,120			
5677 75122120	-GDZ22A -120-H(R)	3	3.5-22.0	120	43	47~63	24	—	46	48	49	69	—	42	GDP-22R	2	69,120	FDC-22AA	S-5R	L-6T
5677 75122150	-150-H(R)	3	3.5-22.0	150	73	47~93	24	—	46	48	49	69	—	42	GDP-22R	2.3	72,360			
5677 77007090	HSK100A -GDZ07 - 90-H(R)	1	0.5-7.0	90	30	22~45	—	46	20	—	23	41	84	—	HDP-07R		69,120	FDC-07AA	S-0R	L-3T
5677 77007120	-120-H(R)	1	0.5-7.0	120	60	22~45	—	76	20	—	23	41	84	—	HDP-07R		70,200			
5677 77007135	-135-H(R)	1	0.5-7.0	135	75	22~45	—	91	20	—	23	41	84	—	HDP-07R		71,280			
5677 77009090	-GDZ09 - 90-H(R)	1	2.5-9.0	90	30	27~45	18	46	26	28	29	45	84	—	GDP-09R		69,120	FDC-09AA	S-1R	L-3T
5677 77009120	-120-H(R)	1	2.5-9.0	120	60	27~57	18	76	26	28	29	45	84	—	GDP-09R		70,200			
5677 77009135	-135-H(R)	1	2.5-9.0	135	75	27~57	18	91	26	28	29	45	84	—	GDP-09R		71,280			
5677 77012105	-GDZ12 -105-H(R)	1	2.5-12.0	105	41	33~45	19	61	30	32	34	56	84	—	GDP-12R		76,680	FDC-12AA	S-3R	L-4T
5677 77012120	-120-H(R)	1	2.5-12.0	120	56	33~60	19	76	30	32	34	56	84	—	GDP-12R		77,220			
5677 77012150	-150-H(R)	1	2.5-12.0	150	86	33~69	19	106	30	32	34	56	84	—	GDP-12R	3.3	79,920			
5677 77016105	-GDZ16 -105-H(R)	1	3.5-16.0	105	41	38~47	19	61	35	37	38	62	84	—	GDP-16R		76,680	FDC-16AA	S-4R	L-4T
5677 77016120	-120-H(R)	1	3.5-16.0	120	56	38~62	19	76	35	37	38	62	84	—	GDP-16R		77,760			
5677 77016150	-150-H(R)	1	3.5-16.0	150	86	38~82	19	106	35	37	38	62	84	—	GDP-16R		80,460			
5677 77122105	-GDZ22A -105-H(R)	1	3.5-22.0	105	37	65	24	61	46	48	49	76	84	—	GDP-22R		77,220	FDC-22AA	S-5R	L-6T
5677 77122120	-120-H(R)	1	3.5-22.0	120	52	47~57	24	76	46	48	49	76	84	—	GDP-22R	3.7	78,300			
5677 77122150	-150-H(R)	1	3.5-22.0	150	82	47~87	24	106	46	48	49	76	84	—	GDP-22R		80,460			

HSK63A、HSK100Aには標準でマニュアルクランプ穴が空いています。
HSK63A, HSK100A have manual clamp holes in the shank.

- コレット、レンチ、プリセットスクリュー、振れ調整レンチは別途ご注文下さい。
 - コレットは必ず AA 級をご使用下さい。
 - クーラントコレット (FDC-OH、C、MS) とタング付刃具併用時の最低挿入長は P. 097 を参照下さい。
 - L3 はプリセットスクリューを使用した時の値です。
 - キャップの締め付けトルクに関しては、P. 554 を参照ください。
- Collet, preset screw, wrench and adjustment wrench are sold separately.
 - Always use AA class collet.
 - Refer to P. 097 for minimum tool insertion length in case of using our coolant collets (OH,C or MS).
 - "L3" indicates dimension when using with a preset screw.
 - See P. 554 for standard tightening torque.

FDC コレット FDC Collet P. 092	レンチ Wrench P. 098	プリセットスクリュー Preset screw P. 100	振れ調整レンチ Adjustment wrench P. 099
			

ご注文例 Ordering Example

マニュアルクランプ穴無し (HSK40A, HSK50A)
Without manual clamping hole (HSK40A, HSK50A)

HSK40A - GDZ07 - 90 (R)
 シャンクサイズ 最大コレット内径 突き出し長さ(L) RCキャップ仕様
 Shank size Max. collet I.D. Projection length with RC Nut

ご注文例 Ordering Example

マニュアルクランプ穴付き (HSK63A, HSK100A)
With manual clamping hole (HSK63A, HSK100A)

HSK63A - GDZ07 - 90 - H (R)
 シャンクサイズ 最大コレット内径 突き出し長さ(L) マニュアルクランプ穴付 RCキャップ仕様
 Shank size Max. collet I.D. Projection length With manual clamping hole with RC Nut

BT
AHO-A
HSK-A/E/F/C
HSK-T
C
UTS
ST
専用機
関連機器
プシュ・メントリ
ミリングチャック
Milling Chuck
コレットホルダ
Collet Holder
ゼロホルダ
Zero Holder
ハイドロチャック
Hydraulic Chuck
シリンカチャック
Shrink Fit
タッピングチャック
Tapping Chuck
アーバ類
Arbors
マルチホーンシステム
Multihorn tool system
機能付きホルダ
Function Holder
HSK E
HSK F
HSK C
シャンク規格
Tool Shank Dimensions