

**New Design & Unique Construction**



- Wellock MC Mechanical Power Vise is most suitable for VMC & HMC.
- Patented Force Adjustable System makes the force setting easier & steadier, moreover, it has constant pressure function & over pressure protection.
- Patented Mechanical Booster is fully sealed against dust, chips and cutting fluid for extended life time.
- Wellock Semi-spherical segment eliminate deflection and lift.



**High & Excellent Rigidity**

- Rigid and tensile ductile iron FCD-60 (80,000PSI) vise body. Slide surface flame hardened to HS65° to maintain the accuracy. S50C jaw-plate has been Carburizing heat treated the hardness to HRC54°.
- 4 different clamping positions.
- Unique design facilitates the evacuation of chips.

*always better*

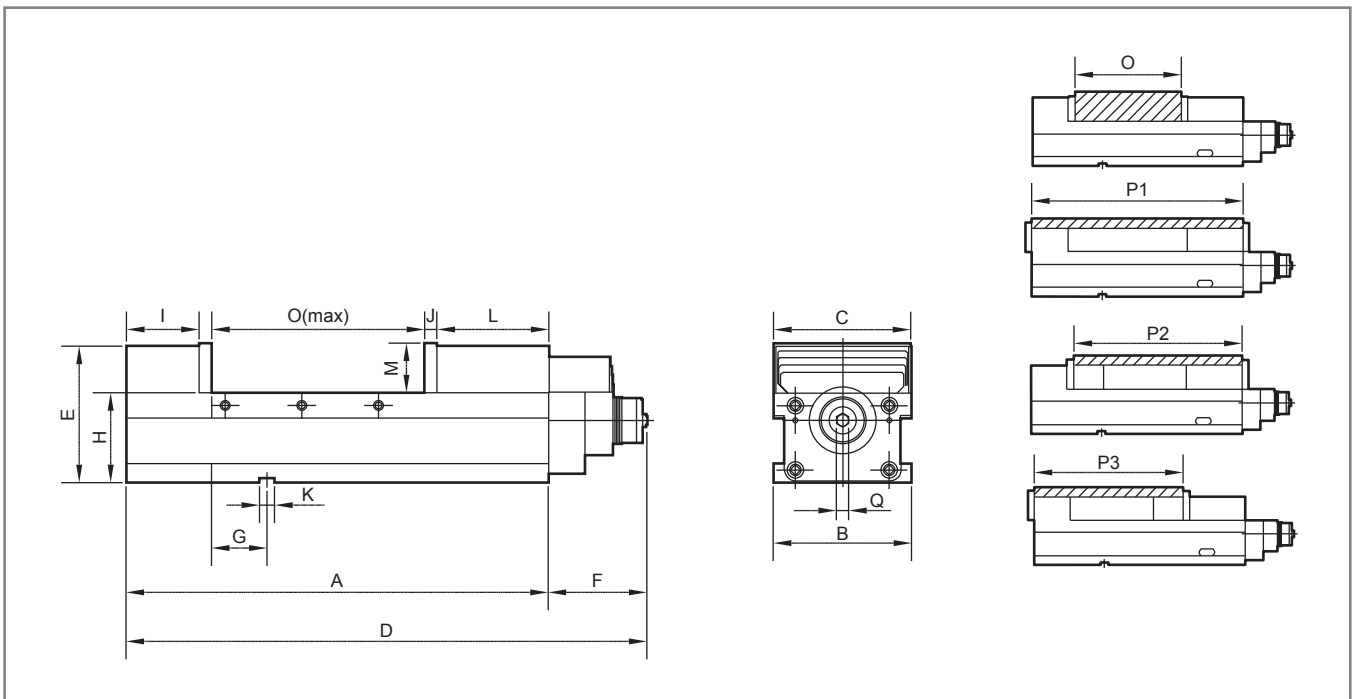

Order No.	A	B	C	D	E	F	G	H	I	J	K	L	M	N	O	P1	P2	P3	Clamping Force	Weight
AVM-160G/HV	495	161	160	610	160	115	65	105	85	15	18	130	58	19	250	250-480	250-370	250-330	57 KN	55 kg
AVM-200G/HV	580	201	200	708	170	128	85	110	90	18	18	150	63	19	290	290-550	290-430	290-370	67 KN	78 kg

\* G: General, HV: Horizontal & Vertical.