

How it works

The NOBUR[®] Tool is a manually actuated deburring and chamfering tool for use where production requirements are low. The tool is used on multi-walled parts and on intersecting holes. It will remove severe burrs and will produce non-qualified chamfers. The tool body pilots in the hole to be deburred. A quick-action

sliding sleeve extends the retractable, double-edged cutting blade to deburr or chamfer the front, back, or both sides of holes, in one pass of the tool.

Since the tool is manually actuated while the spindle continues to run, there is no "on-off" down time.

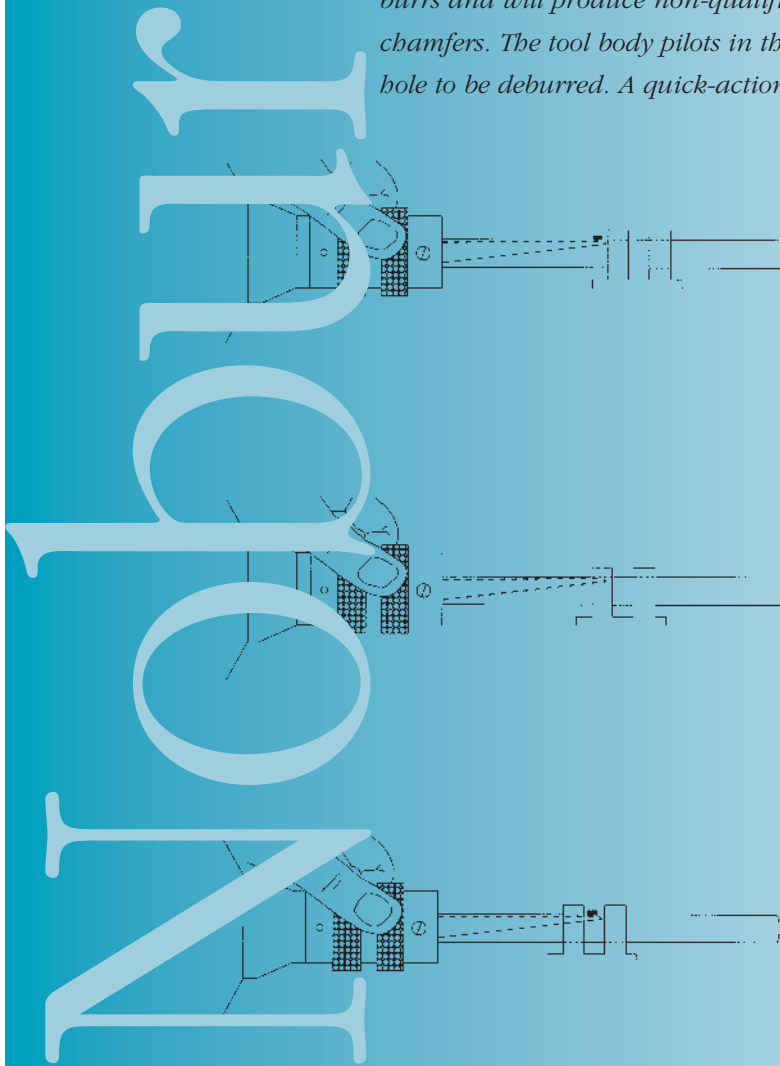

1. The tool should be running in a spindle with the cutting blade in the extended position. The tool is fed into the workpiece. The burr on the outer edge of the first wall is quickly and easily removed.

2. The sliding sleeve is moved backwards to retract the blade. The workpiece is advanced to such a position that, when the blade is again extended by a forward movement of the sleeve, it will lie between the two walls. The burr on the inner edge of the first wall is then easily removed.

3. Continued advancement of the tool allows the inner edge of the second wall to be deburred. The sleeve is moved backwards once again to retract the blade so that it can pass through the hole in the second wall. The blade is again extended to deburr the outer edge of the second wall.

The above steps can be repeated as many times as necessary, depending upon the number of walls in the part. Work is performed continuously, without having to stop the spindle.

Design features

The NOBUR Tool has a free-rolling knurled sleeve, mounted on ball bearings, which allows for fast and easy manual retraction and extension of the blade. The pilot is chrome-plated for long tool life.

Standard sizes range from 3/32 to one inch (2.38 to 25.4mm).
Work lengths range from 9/16 to 4-3/4 inch (14.28 to 120.65mm).



Blade options for intersecting holes

Three different blade options are available for intersecting hole applications. Blade selection is based upon the ratio of the diameters of the two holes (refer to page 27).

Special designs available

Custom tools – including altered standards and special sizes and designs – are available upon request. Please furnish a part print and request a quotation.

Standard tool specifications

Nobur® Tool

| WITH STANDARD CUTTER | | WITH MODIFIED CUTTER-1* | | WITH MODIFIED CUTTER-2** | | Hole Size | | "A" Working Depth | | "B" Pilot Length | | "C" Shank Diameter | | "D" Overall | |
|----------------------|---------------|-------------------------|---------------|--------------------------|---------------|-----------|-------|-------------------|--------|------------------|-------|--------------------|-------|-------------|--------|
| Tool Number | Chamfer Angle | Tool Number | Chamfer Angle | Tool Number | Chamfer Angle | in. | mm | in. | mm | in. | mm | in. | mm | in. | mm |
| DS 3/32 | 45° | DS 3/32-1 | 45° | DS 3/32-2 | 45° | .093 | 2.38 | .56 | 14.28 | 2.43 | 61.91 | .375 | 9.52 | 6.12 | 155.57 |
| DS 1/8 | 20° | DS 1/8-1 | 45° | DS 1/8-2 | 45° | .125 | 3.17 | 1.50 | 38.1 | 3.12 | 79.37 | .375 | 9.52 | 6.81 | 173.03 |
| DS 5/32 | 20° | DS 5/32-1 | 45° | DS 5/32-2 | 45° | .156 | 3.97 | 1.50 | 38.1 | 3.12 | 79.37 | .375 | 9.52 | 6.81 | 173.03 |
| DS 3/16 | 20° | DS 3/16-1 | 45° | DS 3/16-2 | 45° | .187 | 4.76 | 1.50 | 38.1 | 3.12 | 79.37 | .375 | 9.52 | 6.81 | 173.03 |
| DS #10 | 20° | DS #10-1 | 45° | DS #10-2 | 45° | .193 | 4.91 | 1.50 | 38.1 | 3.12 | 79.37 | .375 | 9.52 | 6.81 | 173.03 |
| AS 3/16 | 20° | AS 3/16-1 | 45° | AS 3/16-2 | 45° | .187 | 4.76 | 1.75 | 44.45 | 4.00 | 101.6 | .500 | 12.7 | 7.81 | 198.43 |
| AS #10 | 20° | AS #10-1 | 45° | AS #10-2 | 45° | .193 | 4.91 | 1.75 | 44.45 | 4.00 | 101.6 | .500 | 12.7 | 7.81 | 198.43 |
| AS 7/32 | 20° | AS 7/32-1 | 45° | AS 7/32-2 | 45° | .218 | 5.55 | 1.75 | 44.45 | 4.00 | 101.6 | .500 | 12.7 | 7.81 | 198.43 |
| AS 1/4 | 20° | AS 1/4-1 | 45° | AS 1/4-2 | 45° | .250 | 6.35 | 1.75 | 44.45 | 4.00 | 101.6 | .500 | 12.7 | 7.81 | 198.43 |
| AS 9/32 | 20° | AS 9/32-1 | 45° | AS 9/32-2 | 45° | .281 | 7.14 | 1.75 | 44.45 | 4.00 | 101.6 | .500 | 12.7 | 7.81 | 198.43 |
| AS 5/16 | 20° | AS 5/16-1 | 45° | AS 5/16-2 | 45° | .312 | 7.94 | 1.75 | 44.45 | 4.00 | 101.6 | .500 | 12.7 | 7.81 | 198.43 |
| AS 11/32 | 20° | AS 11/32-1 | 45° | AS 11/32-2 | 45° | .343 | 8.73 | 1.75 | 44.45 | 4.00 | 101.6 | .500 | 12.7 | 7.81 | 198.43 |
| AS 3/8 | 30° | AS 3/8-1 | 45° | AS 3/8-2 | 45° | .375 | 9.52 | 2.75 | 69.85 | 6.00 | 152.4 | .500 | 12.7 | 9.81 | 249.23 |
| AS 13/32 | 30° | AS 13/32-1 | 45° | AS 13/32-2 | 45° | .406 | 10.31 | 2.75 | 69.85 | 6.00 | 152.4 | .500 | 12.7 | 9.81 | 249.23 |
| AS 7/16 | 30° | AS 7/16-1 | 45° | AS 7/16-2 | 45° | .437 | 11.11 | 2.75 | 69.85 | 6.00 | 152.4 | .500 | 12.7 | 9.81 | 249.23 |
| AS 15/32 | 30° | AS 15/32-1 | 45° | AS 15/32-2 | 45° | .468 | 11.9 | 2.75 | 69.85 | 6.00 | 152.4 | .500 | 12.7 | 9.81 | 249.23 |
| AS 1/2 | 30° | AS 1/2-1 | 45° | AS 1/2-2 | 45° | .500 | 12.7 | 2.75 | 69.85 | 6.00 | 152.4 | .500 | 12.7 | 9.81 | 249.23 |
| AS 9/16 | 30° | AS 9/16-1 | 45° | AS 9/16-2 | 45° | .562 | 14.28 | 3.75 | 95.25 | 8.00 | 203.2 | .500 | 12.7 | 11.81 | 300.03 |
| AS 5/8 | 30° | AS 5/8-1 | 45° | AS 5/8-2 | 45° | .625 | 15.87 | 3.75 | 95.25 | 8.00 | 203.2 | .500 | 12.7 | 11.81 | 300.03 |
| AS 11/16 | 30° | AS 11/16-1 | 45° | AS 11/16-2 | 45° | .687 | 17.46 | 3.75 | 95.25 | 8.00 | 203.2 | .500 | 12.7 | 11.81 | 300.03 |
| AS 3/4 | 30° | AS 3/4-1 | 45° | AS 3/4-2 | 45° | .750 | 19.05 | 3.75 | 95.25 | 8.00 | 203.2 | .500 | 12.7 | 11.81 | 300.03 |
| CS 13/16 | 30° | CS 13/16-1 | 45° | CS 13/16-2 | 45° | .812 | 20.63 | 4.75 | 120.65 | 10.00 | 254 | .625 | 15.87 | 14.37 | 365.12 |
| CS 7/8 | 30° | CS 7/8-1 | 45° | CS 7/8-2 | 45° | .875 | 22.22 | 4.75 | 120.65 | 10.00 | 254 | .625 | 15.87 | 14.37 | 365.12 |
| CS 15/16 | 30° | CS 15/16-1 | 45° | CS 15/16-2 | 45° | .937 | 23.81 | 4.75 | 120.65 | 10.00 | 254 | .625 | 15.87 | 14.37 | 365.12 |
| CS 1 | 30° | CS 1-1 | 45° | CS 1-2 | 45° | 1.000 | 25.4 | 4.75 | 120.65 | 10.00 | 254 | .625 | 15.87 | 14.37 | 365.12 |

Note: The DS 3/16 and DS #10 duplicate sizes offered in the "AS" series. The "DS" tool offers more rigid blade support than the comparable "AS" tool and is recommended for applications in steel and for heavy burr removal.

*Used when larger hole is between 6 and 12 diameters larger than smaller hole

**Used when larger hole is between 2-3/4 to 6 diameters greater than smaller hole.

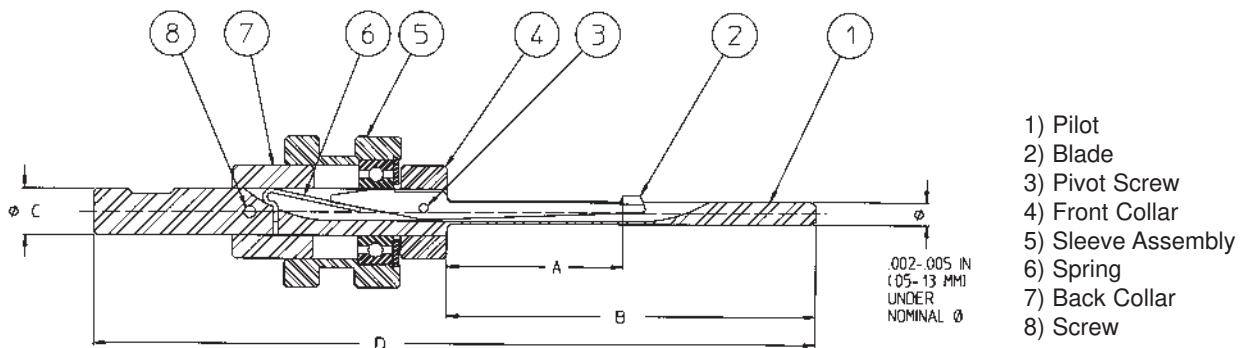

Blade data

Blades for NOBUR® Tools are manufactured from hardened and precision ground high-speed steel. Three styles are available: standard, and two modified designs (see below for application parameters). For applications other than intersecting holes, the standard blade is used.

Blades for intersecting hole applications

Intersecting holes can sometimes create problems when using the NOBUR Tool with the standard blade. The following guidelines apply:

Standard blades may be used for intersecting hole applications where the larger hole “B” is 12 or more times *greater* than the smaller hole “A” (refer to Figure 4).

Modified standard blades are available from stock for intersecting hole applications where the following conditions exist:

- **Modified blade No. 1** is recommended for intersecting holes where the diameter of the larger hole “B” is between 6 to 12 times *greater* than the smaller hole “A.”
- **Modified blade No. 2** is recommended for intersecting holes where the larger hole “B” is 2-3/4 to 6 times *greater* than the smaller hole “A.” (Operating speeds from 25-75 RPM are also recommended for applications within this range of intersecting hole diameter ratios.)

Note: The NOBUR Tool is **not** recommended for lower ratios of diameter or for holes which do not intersect squarely.

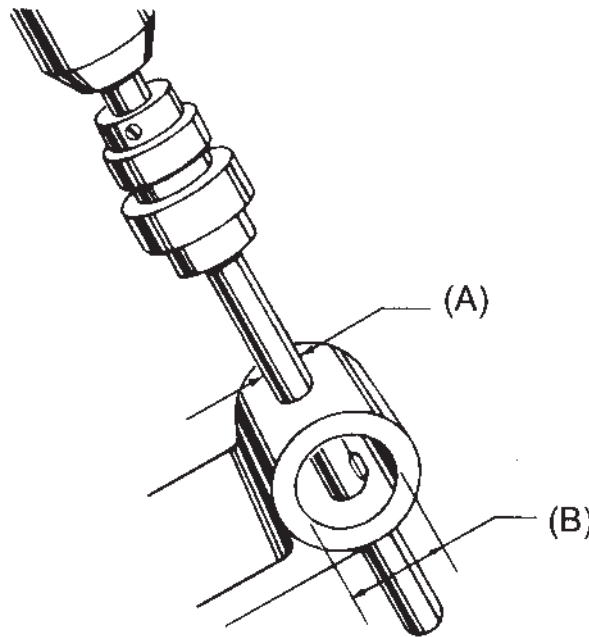

Figure 4

Tool operating recommendations

Tool operation

NOBUR® Tools can be run on a drill press, lathe, or any rotating spindle.

Material types

NOBUR Tools can be applied on steel, stainless steel, brass, bronze, aluminum, or virtually any ferrous or non-ferrous materials.

Speeds

Low operating speeds are recommended for the NOBUR Tool. A range of 50 to 650 RPM is suggested, with slower speeds required for larger tool sizes and heavy parts.

High spindle speeds will not result in faster production, since only three or four revolutions of the tool are required to remove the burr. High spindle speeds are likely to dull the blade edge, create excessive wear on the pilot shaft, or cause chatter. The part should be supported as necessary.

Blade replacement and regrinding

The NOBUR Tool blade can be easily replaced by following this procedure (refer to the schematic drawing on page 26):

For tool numbers #DS 1/8 to #DS 10:

- Remove the back collar.
- Slide the knurled sleeve back to where it just drops free onto the smaller shank diameter.
- Restrict further movement of the blade at this point, and complete the removal of the sleeve.
- Lift the blade out and replace.

For tool numbers #AS 3/16 to #AS 1/2:

- Slide the knurled sleeve against the back collar so that the blade is retracted within the pilot shaft.
- Remove the pivot screw. This frees the front collar and permits the blade to be lifted out.
- Replace the blade. To re-assemble, the cam edge of the blade must be inserted so as to depress the end of the spring which extends beyond the sleeve.
- Align the front collar and replace the pivot screw. A zero (0) mark is stamped on the front collar of tools #AS 5/16 and smaller to indicate that it is to be positioned in line with the slot on the pilot shaft.

For tool numbers #AS 9/16 to #AS 3/4:

- Remove the screw from the back collar. Remove the back collar and sleeve. Remove the pivot screw from the front collar and lift the blade out for replacement.
- To re-assemble, replace parts in reverse order. Insert the blade first in such a manner that the spring is depressed.

For tool numbers, #CS 13/16 to #CS 1:

- Slide the knurled sleeve against the back collar. Remove the pivot screw and lift the blade out and replace.
- To re-assemble, the cam edge of the blade must be inserted in such a manner as to depress the end of the spring which extends beyond the sleeve.

Replacement blades for NOBUR Tools are inexpensive; however, blades may be reground in the user's shop. The blade must be kept

sharp, since a dull blade takes longer to cut and the operator will tend to apply excessive pressure against the work. Refer to Figure 5 for proper regrind procedure.

Short front pilot

It may be necessary to shorten the front pilot to accommodate blind holes or obstructions. The pilot should be cut off beyond the slot from which the blade projects.

Tool maintenance

Inspect the tool periodically for chips and foreign particles in the slot of the pilot shaft. Clean as necessary.

A few drops of lubricating oil applied between the sliding sleeve and the back collar will extend the life of the bearing.

Resharpener of the cutting blade is accomplished by grinding the faces "G" and "H". The following table is offered as a guide to original factory standards.

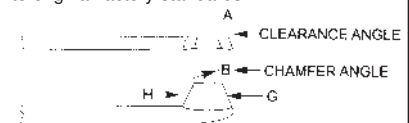

| TOOL SIZES (Inclusive Range) | ANGLE A | ANGLE B |
|---------------------------------|---------------|-----------------|
| DS 3/32 | 6-1/2° | 45° |
| DS 1/8 - DS#10 | 6-1/2° | 20° |
| AS 3/16 - AS 11/32 | 6-1/2° | 20° |
| AS 3/8 - AS 1/2 | 6-1/2° | 30° |
| AS 9/16 - AS 3/4 | 5° | 30° |
| CS 13/16 - CS 1 | Primary 3° | Secondary 5° |

Figure 5